

An overview of particulate dry deposition: measuring methods, deposition velocity and controlling factors

S. Mariraj Mohan¹

Received: 21 March 2015 / Revised: 8 September 2015 / Accepted: 28 September 2015 / Published online: 12 October 2015
© Islamic Azad University (IAU) 2015

Abstract Much importance was given to dry deposition over the past few decades as it deteriorated the environmental conditions and resulted in subsequent health effects. This paper starts with an overall scenario of dry deposition research; it focuses on: various particulate dry deposition flux measurement methods, comparison of various published numerical values on dry deposition velocity and factors controlling dry deposition velocity. This work provides a technical overview to research studies on the current state of dry deposition and limitations of various measurement methods. Relationship between dry deposition flux and particle concentration is discussed with the help of previous works. Various mathematical models used to predict dry deposition velocity are discussed. Dry deposition velocity of particulates around the world is compared to gain perspective on factors influencing dry deposition.

Keywords Dry deposition flux · Dry deposition velocity · Dry deposition model · Particulate matter · Meteorological factor

Introduction

The process of removing particles or gases from the atmosphere through the delivery of mass to the surface by non-precipitation is defined as “dry deposition” (Dolske and Gatz 1985). Dry deposition is an important pathway for

the transfer of pollutants from the atmosphere to natural surfaces. Dry deposition process can be explained in three steps (Wu et al. 1992)

1. Aerodynamic transport.
2. Boundary layer transport.
3. Uptake by receptor.

Interest in atmospheric deposition has increased over the past decade due to concern about the effects of the deposition material entering the environment and subsequent health effects. Dry deposition is an important pathway for transfer of pollutants. The movement of pollutants in this pathway in environment needs to be understood.

Because of urbanization and industrialization, the formation of pollutants is quite inevitable. The pollutants would be deposited on trees, grasses, crops, water bodies, buildings and human beings. Because of the deposition, there are both ecological and non-ecological impacts (visibility reduction). There have been several studies (Dloske 1995) to assess the deposition of atmospheric pollutants to monuments, statues and buildings. Dry deposition of atmospheric pollutants upon natural water contributes to water quality degradation and may harm aquatic ecosystems (Zufall et al. 1998). Deposition can be either dry or wet. Wet deposition can be expected during rains.

Air pollutants can be harmful to human health in the following ways: (1) They can be adsorbed into human lung tissues during breathing and (2) they can be transported into various terrestrial and aquatic ecosystems through dry and wet deposition processes and cause subsequent health effects when products from these ecosystems are consumed by humans. Quantifying the amount of dry and wet deposition is critical since these deposition processes determine the pollutant species’ lifetime in air and their input to

✉ S. Mariraj Mohan
mari_sundar@yahoo.com

¹ Alagappa Chettiar College of Engineering and Technology, Karaikudi, Tamil Nadu 630 004, India

various ecosystems. Due to high cost and technical difficulties associated with conducting direct measurements of dry deposition, inferential method has been commonly used to estimate dry deposition (Zhang et al. 2012). Particulate matter smaller than 3.0 μm is easily transported through the upper respiratory tract into the bronchioles and alveoli of the lungs and poses direct health effect (Yang et al. 1999). Several studies suggested that uncertainties in dry deposition estimates are on the order of factor 2, on an annual basis, for commonly studied sulfur and nitrogen species (Flechard et al. 2011; Schwede et al. 2011). The uncertainties could be larger for particle species than for gaseous species due to strong dependence of the particle dry deposition velocity on the particle size (Petroff and Zhang 2010).

Atmospheric deposition results from the transport and accumulation of particle onto a surface during the periods of no precipitation. Dry deposition has gained a great deal of interest from researchers due to its effects on the environment; consequently, there have been significant efforts to measure or estimate dry deposition using a variety of techniques. Atmospheric deposition influences the fate of airborne toxics and often controls the transfer of material from the atmosphere to natural surfaces. Dry deposition provides significant mechanism for the removal of particles from the atmosphere and is an important pathway for the loading of toxic pollutants onto the environment. The objective of this paper is to provide technical insight to researchers by: (1) reviewing various dry deposition literature, (2) discussing various factors influencing dry deposition, (3) tabulating and comparing numerical values of dry deposition flux around the world, (4) giving exposure to researchers of various mathematical models available to predict dry deposition in terms of dry deposition velocity and exploring suitability of the model to different topographical conditions.

Various sources of pollutants

Airborne particles are produced by both natural and anthropogenic sources. They can be produced either by direct emission to atmosphere (primary aerosols) or by physical and chemical process within the atmosphere (secondary aerosols) (note that aerosol and particle are used interchangeably here). Fine particles are mainly contributed by industrial and residential emission or by vegetation fires (Zhang and Vet 2006). Coarse particles include soil dust and salt particles (Kaufman et al. 2002). Different aerosol species from the same continent may have different transport pathways associated with the continental outflow and aerosol vertical profiles (Sataka et al. 2004). Atmospheric particles have strong impacts on climatic and environmental issues. These particles have

direct (scattering or absorption of solar radiation) and indirect (increasing cloud condensation nuclei) effects on climate. Atmospheric deposition of particles delivers atmospheric loads of many compounds (e.g., sulfate, nitrate, ammonium, base cations and heavy metals) to ecosystems (Ruijgrok et al. 1995). Atmospheric particles are also responsible for many urban air pollution-related problems (e.g., decreased visibility and human problems such as respiratory illnesses (USEPA 1996).

Most of the emission sources in urban area are fugitive dust, which can arise from a wide variety of sources including paved and unpaved roads, industrial areas, construction and agricultural activities. Fugitive dust is usually associated with coarse fraction ($>2.5 \mu\text{m}$) of atmospheric aerosol (Sofuoglu et al. 1998). The process of dry deposition of airborne pollutants is influenced by various physical, chemical and biological factors that can cause large variations in deposition on both small and large scales of time and space (Ould-Dada et al. 2002).

Dry deposition of atmospheric pollutants, especially mercury, imposes considerable impact on terrestrial and aquatic ecosystems. It is well known that vapor-phase Hg constitutes the vast majority of atmospheric Hg burden, but particulate-phase Hg may actually play a disproportionately large role in the amount of Hg in various environment compartments (Fang et al. 2001). Dry deposition of ambient particles is thought to be an important pathway for the introduction of toxic trace elements and heavy metals into aquatic ecosystem (Yun et al. 2002).

To thoroughly understand the above-mentioned problems, particles emission, transport, transformation and removal mechanisms have to be quantified at multiple scales. Dry and wet depositions are the two major removal mechanisms for atmospheric particles. Dry deposition is the removal process though which particles are taken up by the earth's surface. In the process of wet deposition, particles are delivered to the surface via precipitation. Both the mechanisms are strongly size-dependent with removal rates of particles from the atmosphere differing by several orders of magnitude for different particle sizes (Seinfeld and Pandis 1997).

Background

Air Resource Laboratory (ARL) is a leader in the development and operation of dry deposition networks. Since 1984, the Atmospheric Turbulence and Diffusion Division in Oak Ridge has been operating a network specifically designed to get around the major problem confronting dry deposition monitoring activities, as there is no existing method that is suitable for routine direct measurement. The nested network that was developed consisted of a small number of research sites supporting a larger array of

stations making simpler but more routine observations. The Dry Deposition Inferential Method (DDIM) that was developed remains the central routine analytical tool of the ongoing National Oceanic Atmospheric Administration's (NOAA) dry deposition trial network. It is now identified as the dry deposition component of the Atmospheric Integrated Research Monitoring Network (AIRMoN). This network started with six sites; thirteen stations are now operating.

Then, the National Dry Deposition Network (NDDN) was established in 1986 to document the magnitude, spatial variability and trends in dry deposition across the USA. Currently, the network operates as a component of the Clean Air Status and Trends Network (CASTNet). Dry deposition is not measured directly in CASTNet, but is determined by an inferential approach (that is, fluxes are calculated as the product of measured ambient concentration and a modeled deposition velocity). In CASTNet, chemical species included were ozone, sulfate, nitrate, ammonium, sulfur dioxide and nitric acid. The temporal resolution for the ambient concentration measurements and dry deposition flux calculations is hourly for ozone and weekly for the other species.

At the 2009 Fall Meeting in Saratoga Springs, the National Atmospheric Deposition program (NADP) Executive Committee accepted the Atmospheric Mercury Network as an official NADP network.

The Atmospheric Mercury Network (AMNet) established this network of monitoring stations for the purpose of measuring atmospheric mercury fractions, which contribute to dry and total mercury deposition. Sites collect concentrations of atmospheric mercury species from automated, continuous measuring systems.

As with other networks, NADP welcomes the participation of other organizations and scientists. To truly understand the mercury problem, more monitoring information is needed. This section emphasizes the present status of dry deposition research work around the world. ARL Headquarters develops and improves atmospheric dispersion and air quality models, which track the movement of potentially harmful substances. It collects air quality and deposition measurements of selected air quality parameters and provides climate-relevant datasets and assessments of climate variability and trends. It is operated from Silver Spring, Maryland 20910, USA. It is part of NOAA (www.arl.noaa.gov). As far as the Indian context is concerned, no such dry deposition network has been operating to evaluate atmospheric dry deposition of pollutants.

Discussion on various methods of flux measurement

Direct methods are subdivided into surface analysis and atmospheric flux methods. Surface analysis includes foliar

extraction, throughfall and stemflow, watershed mass balance, aerodynamically designed surface, isotopic tracers, snow sampling and cloud droplet collection. The atmospheric flux method includes eddy correlation (tower and aircraft based), gradient method, eddy accumulation, variance technique, aerometric mass balance and multiple artificial tracers (Fairall and Larsen 1984; Zhang and Vet 2006). Throughfall and stemflow have been taken in many countries as simple techniques for the assessment of total deposition flux of oxides of sulfur to forests, although this method can be usually used only during the warm season.

Except in special circumstances, however, most of these direct methods are sufficiently complicated that routine application in a monitoring network is not yet practical. Moreover, routine applicability does not appear likely in the foreseeable future because (a) the chemical sensors necessary are not suitable for routine unattended use, (b) the cost is prohibitive, (c) the requirement of skilled operators is unavoidable and (d) sites for suitable homogeneity are not available. Air pollution concentrations will also be monitored in this method.

There were many different types of surfaces that have been used for collection of atmospheric particles including filter papers, petri dishes, microscopic slides and Teflon plates (Chang et al. 1994). However, there is still no generally acceptable technology for sampling and analyzing dry deposition flux. The quantification of dry deposition flux is difficult because of large spatial and temporal variations. The use of surrogate surface to collect dry deposition is a technique that allows a comparison to be made of measured and modeled data because it can be used to directly access deposited material (Holsen and Noll 1992). Previous usages of solid surface as mentioned above have been used as surrogate surface. These studies have shown that collector geometry has a large impact on the amount of material collected. Dry deposition studies by Noll et al. (1988) showed that a greased strip on the top of a smooth knife-edge plate can be used as a surrogate surface for particle dry deposition measurements. Grease prevents particle bounce. Comparisons between dry depositions measured with this type of surface and dry deposition modeled from simultaneously measured complete size distributions using a multi-step model have been in good agreement. There are a number of problems associated with the use of greased surrogate surfaces for collection of dry deposition compounds that exist in both the gas and the particulate phases. Greased surfaces are not amenable to routine sampling of organic compounds, which are analyzed by gas chromatography due to difficulties in separating the analyte from the grease. In addition, there are uncertainties about the interaction between the grease used to collect particles and the vapor phase of the contaminant. In comparison with greased solid surfaces, water surfaces

exhibit some unique characteristics. Deposition of gaseous pollutants to water is controlled by a combination of atmospheric and surface resistances (Yi et al. 1997). From the above discussion, it could be inferred that surrogate solid surface used to measure dry deposition flux may not be suitable for environment containing vapor phase of pollutant. But in either case (solid surface and water surface sampler) extreme care has to be taken in transporting collected sample to laboratory for analyses. Furthermore, in previous studies, comparison of water to greased surface flux ratio revealed that, for higher molecular weight particulates, this ratio was found to be less than one, whereas for lower molecular weight particulates it was more than one. Based on the literature, comparison of measured and modeled gaseous dry deposition flux by water surface sampler yielded a correlation coefficient of 0.88, which is quite less than the correlation coefficient by surrogate surface. Now, trade-off exists between these two types of surfaces. The use of particular surface strongly depends on the condition of environment where sampling is done.

The geometrical structural arrangement of water surface sampler was selected to provide minimum airflow disruption and to allow comparison with smooth surface samplers. In water surface sampler, no standard criteria were fixed to choose water depth. Water surface sampler having 40 cm diameter and 10 cm depth of bowl was used in the study conducted by Shahin et al. (2002). An additional component required in water surface sampler is a recycling system consisting of water reservoir and pump. Without this important component, continuous exposure of the sampler would saturate the water present in it. In other words, for a given water depth, if pollutant concentration is high at a given sampling location, long-term sampling would saturate the water present in the sampler. In this case, dry deposition flux would be underestimated. To alleviate this problem, retention time of the water can be kept as minimum as possible. But if retention time is small, large quantity of water will be needed to complete the sampling. Hence, limitation of using water surface sampler is that the depth of the sampler to accommodate water should match the sampling time and pollutant concentration of the sampling location. However, surface area of water surface sampler is 15.3 times higher than that of Eagle II arrangement of dry deposition plate. Since water surface sampler assumes more surface area, it could be used for long-term sampling as compared to that of Eagle II arrangement. Brief discussion on Eagle II arrangement is given in “[Standard operating procedure for particulate dry deposition flux, concentration measurements and discussion on sampling time and height](#)” section. To evaluate the ability of water surface sampler to measure particulate-phase dry deposition, deposition of calcium, a crustal element and lead, an anthropogenic element, both the water

surface sampler and the greased surface were compared in the study conducted by Yi et al. (1997). They found that the calcium and lead fluxes from water surface were found to be statistically the same. This finding indicated that both surfaces have similar deposition characteristics for atmospheric particles. Another similarity between these two surfaces is both have smooth surface with sharp leading edge. Dry deposition plate was actually designed after undergoing several wind tunnel experiments. With the help of the experiment, wind pattern over the plate could be evaluated.

Current dry deposition estimation methods often use measured air concentrations and modeled dry deposition velocities. Since the models used to predict dry deposition velocities are complex and require information that is difficult to obtain, dry deposition fluxes are often estimated using particulate concentration and assumed dry deposition velocities. However, there has been no consensus on the appropriate dry deposition velocity. The use of surrogate surface is one approach to directly measure dry deposition (Odabassi et al. 2002).

Goss et al. (2013) developed and tested a marble insert for dry deposition collection. Then, they developed a method for enumerating the collected dry deposition with the flow Cytometer and Microscope (FlowCAM), a dynamic image particle analysis tool. Marble surfaces are preferred for deposition rate estimation as they are suitable for subsequent extraction of particles from them. But in other surrogate surfaces recovery efficiency is usually between 60 and 80 %. Maro et al. (2014) collected aerosol dry deposition on building facades. Deposition of particles on building facades is a relatively slow process. In this type of studies, long-term sampling could not provide representative data as particles may be washed out by rain. It is well known that dry deposition on surfaces results from a combination of several processes such as gravitational settling, Brownian diffusion, impaction, interception, thermophoresis, diffusio-phoresis and electrostatic attraction (Maro et al. 2014). Gravitational settling is expected to play no role in dry deposition on vertical surfaces. Hence, turbulent diffusion could be a prime mechanism of dry deposition. Analysis of dry deposition on a greased surface deposition plate mounted on a building wall may result in overestimation of deposition than that of building facades. Hence, when it comes to applicability (actual deposition of particles on building facades), deposition of particles on a plate should be corrected by some numerical factor depending on the location of the building and the concentration of pollutant in its vicinity. Furthermore, the level of actual surface finish is an important factor to capture/retain particles. As far as Maro et al. (2014) is concerned, particles with size 0.2–4 μm could be collected on vertical surfaces (values are restricted to their sampling

conditions): But on horizontal surfaces, any range of particle size could be collected. To evaluate human exposure and associated health implications, horizontal surface sampling may be used since this type of sampling accounts for the entire size range of particles. But to investigate deterioration of buildings and monuments, sampling on vertical surface could be conducted. In other words, to investigate ecological impact, horizontal surface sampling could be used, whereas to predict non-ecological impact vertical surface sampling could be used. In general, long-term sampling cannot be easily correlated with meteorological conditions since temperature, wind speed and relative humidity may vary over a period of time. On the contrary, short-term sampling can be correlated with meteorological parameters. Hence, sampling performed in controlled environment (not having much dispersion in meteorological conditions) could provide reliable data.

Dry deposition strongly depends on the season and types of surfaces. Hence, various surfaces were tried to evaluate dry deposition flux as discussed before. Surrogate surface with greased stripes has sharp edge that are pointed into wind with a wind vane that minimizes disruption of air-flow, whereas in other surfaces (filter papers, petri dishes, microscopic slides, Teflon plates, vegetation, etc.) this impact plays significant role leading to resuspension of particles. This could pave way for overestimation or underestimation of fluxes. But minimum disruption of air flow would also minimize boundary layer resistance. For this reason, dry deposition plates collect less deposition than that of rougher surfaces.

Another way to evaluate dry deposition fluxes is inferential approach (indirect method). This approach is based on $f = V_d C$. This approach was quite popular in North America for years, since it involves making additional measurements (concentration of particles). This technique permits allowance for site-specific characteristics. From this discussion, it can be said that if dry deposition flux is mathematically expressed as a function of all parameters responsible for it, the resultant equation would improve accuracy of flux determination (after incorporation of concerned parameters, dimensional homogeneity should be maintained on both sides of the equation). In future, some more theoretical/empirical equation is needed to evaluate dry deposition flux by incorporating possible parameters responsible for flux.

Standard operating procedure for particulate dry deposition flux, concentration measurements and discussion on sampling time and height

There are several methods of collection for dry deposition. Sample collection by standard operating procedure (SOP) is briefly discussed here. Dry deposition samples of

atmospheric particles are collected based on “Standard operating procedure for preparation, handling of dry deposition plates: Dry deposition of atmospheric particle.” Dry deposition plates are used to measure mass flux. This standard operating procedure (SOP) addresses the protocol for preparation and handling. The SOP also discusses the quality assurance and quality control measures (Paode and Holsen 1996).

A schematic of dry deposition plate is presented in Fig. 1. The plate is made of polyvinyl chloride and is 21.6 cm long, 7.6 cm wide, 0.65 cm thick with a sharp leading edge ($<10^\circ$ angle) to ensure laminar flow. Each plate is covered with four Mylar strips (5.7 cm \times 1.8 cm) coated with grease to collect impacted particles (Paode and Holsen 1996).

The dry deposition flux is measured using Eagle II dry deposition collectors. This sampler contains two deposition plates mounted on arms that are pointed into the wind with a wind vane. These arrangements are made to allow the plates swing freely in the wind (Shahin et al. 2000). Dry deposition plates were exposed in the field with the help of Eagle II arrangements. Atmospheric particles were deposited onto the strips. The strips were weighed before and after exposure to determine the total mass of particle collected. The mass flux is determined by dividing the

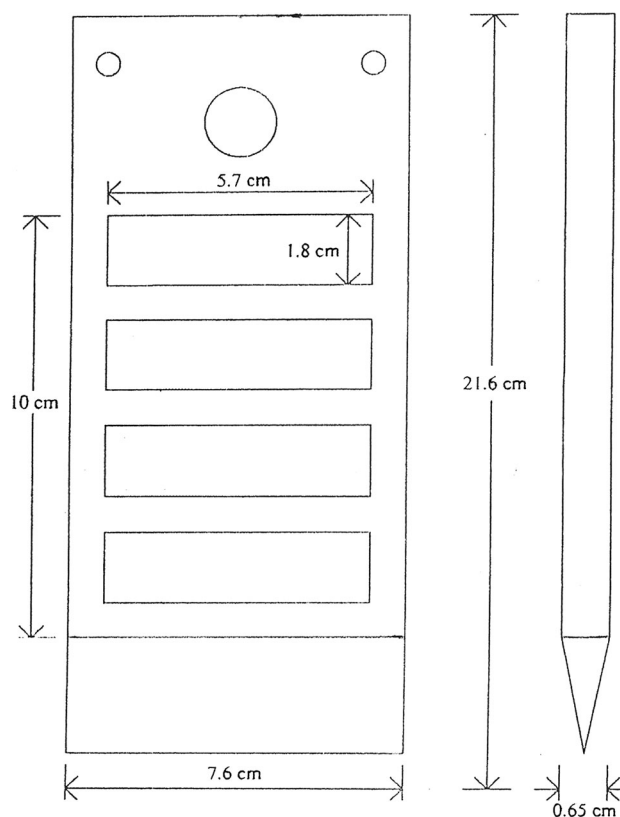

Fig. 1 Top and side view of dry deposition plate

collected mass by the exposure time and the exposed surface area. As per Eq. (1) (Lestari et al. 2003), dry deposition flux is calculated.

$$f = \frac{m}{at} \quad (1)$$

where f = dry deposition flux (mg/m²/h); m = mass collected on greased strip (mg); a = exposed surface area over number of strips (m²); t = duration of sampling (h).

Sampling time is usually varied depending on local standard. For example, as far as Indian scenario is concerned, nighttime is designated between 22:00 to 07:00 hours as outlined in the Ministry of Environment and Forest Notification S.O. 123 (E) dated February 14, 2000. Remaining 15 h is daytime. But in some studies day and night dry deposition samples and particle concentration were collected from 08:00 to 20:00 and 20:00 to 08:00, respectively, as suggested by Holsen et al. (1991). They mentioned that the collection of day and night samples as per the above time limits would be covering a wide range of atmospheric conditions to be evaluated. Also, equal time of sampling for day and night may lead to proper interpretation of the data for day and night samples. Dry deposition sample is collected during period with no rain or no threat of rain.

Conventionally, dry deposition samples are taken at roof top of a building. But there has been no rigid rule about what height is datum to ensure a true representative of samples. There have been several studies in which dry deposition samples were collected from three-storey (12 m) and four-storey (14 m) buildings (Lee et al. 1996; Chang et al. 1994). Much focus is needed to come out with height ranges to obtain true representative of dry deposition samples for a given location. Furthermore, if particulate concentration is measured simultaneously with the help of high volume sampler, the sampler should be placed at a sufficiently large distance. The reason for prescribing this is because of continuous duty blower arrangement of high volume sampler to suck in air stream. If high volume sampler is placed close to dry deposition collection device, the suction could bring more particles to the strip, paving way for overestimation of dry deposition flux. In addition to this, since dry deposition sample and particle concentration are measured simultaneously at a given location, strong correlation must be existing between the mass of particle collected on strip and the mass of particle collected on the glass fiber filter of high volume sampler.

In this type of gravimetric analysis, background concentration is usually monitored using operational blanks (unexposed strips), which is processed simultaneously with field samples. At least 10–15 % of the samples are analyzed in duplicate and spiked with a known amount of material to calculate recovery efficiency. If the recovery

efficiency is more than 90 %, it substantiates reproducibility of experiment.

Particle concentration is collected on 20.3 × 25.4 cm² glass fiber filter using a high volume sampler (Odabassi et al. 2002). Airborne particulate matter is an ensemble of solid particles suspended and dispersed in air. The properties of these particles vary in terms of chemical composition, morphology (size/shape), optical parameters (color/light scattering) and electrical characteristics (charge, resistance). Particles, which in general are non-spherical, are classified in terms of their aerodynamic diameter. This is defined as the diameter of a sphere of density 1 g/cc having a settling velocity equal to that of the particle in question. To collect particles, PS-1 sampler could also be used. PS-1 is a completed air sampling system designed to collect suspended airborne particles (Fang et al. 2014).

Dry deposition results of several dynamical and thermal processes have been extensively studied on natural surfaces. Instead of taking dry deposition sample in a field, another form of this type of research is taking emission of aerosol plume at a short distance upwind from an array of test plates. Since quantity of emission is known, atmospheric transfer coefficient is calculated (Maro et al. 2004, 2014). Measurement of background concentration is the constraint associated with this kind of research work, as atmospheric particles also contribute to dry deposition flux. If this experiment is performed in a laboratory, field environmental conditions (wind speed, temperature, etc.) could not be exactly simulated.

Measurement of particle size

To understand the nature of particle contributing to dry deposition or other health effects, knowledge on particle size is necessary. Conventionally, particle size is interchangeably used as particle diameter. At the outset, when no other sophisticated instrument was available, microscopic count data were used to generate particle size distribution. Modern instruments are as follows: The scanning electron microscope (SEM) and energy-dispersive X-ray detector (EDX) provide size and chemical data for particles between 0.2 and 300 μm in diameter (Zufall et al. 1998). Characterization of particulate matter can be done by Noll Rotary Impactor (NRI). The limitation of NRI is that it is capable of characterizing coarse particles ranging from 6.5 to 100 μm. To characterize fine particles, micro-orifice uniform deposit impactor (MOUDI) can be used. MOUDI is available with 8 stages or 10 stages. Available cut size diameter ranges from 0.05 to 10 μm (Fang et al. 1997). NRI and MOUDI could be operated together to collect/characterize wide range of particles. Concentration of particles at the given size range can be obtained through

NRI and MOUDI. The concentration at overlap size ranges measured by both MOUDI and NRI is usually presented by the averaged data.

Analysis of chemical elements

Based on the previous work, it could be construed that dry deposition flux of primarily crustal elements (Si, Al, Ca, Mg, etc.) is found to be in coarse particle size range, and primarily anthropogenic elements (V, Cr, Cu, Mo, Ba, etc.) are found in fine particle size range. However, there were some exceptions. As a result, higher dry deposition flux can be expected for crustal elements than that for anthropogenic elements. Each and every element has its own source. For instance, if higher value of Ca exists in collected particles, it may be from cement due to construction activities in the nearby areas or from cement factory nearby. Higher lead value found may be from leaded gasoline. Similarly, higher Na value may be possibly from marine aerosol contribution. Crustal elements in the atmosphere are usually derived from fugitive dust emissions (emissions from paved or unpaved roads, industrial area, construction and agricultural activities). These elements can serve as a fingerprint for this source.

Either crustal or anthropogenic elements are usually collected by the dichotomous sampler and measured by X-ray fluorescence (XRF). Standard operating procedure in this regard can be obtained from Kellogg 1992. These elements can also be measured by inductively coupled plasma (ICP) after extraction procedure from collected particles. Both instruments can measure these elements accurately, but ICP is slightly better since systematic errors are easier to eliminate and random measurement error can be low. Furthermore, for high concentration of elements atomic absorption spectrophotometer (AAS) and for lower concentration/trace elements ICP can be used since AAS is less sensitive and ICP is more sensitive.

Crustal elements are not usually controllable. Once released into the atmosphere, they may find some mechanism (dry/wet deposition) to reach their destination. But anthropogenic elements are controllable through technology and by legal means. Furthermore, crustal elements are partially soluble, while anthropogenic elements are highly soluble at precipitation pH values in the ranges of 3.5–5.0 (Zheng et al. 2005). Hence, in this condition, after precipitation, contribution of crustal elements in dry deposition will be higher than that of anthropogenic elements. For most chemical elements extracted from deposited particles, nitric acid is usually used. Nitric acid possesses different dissolution capacity for different elements. Hence, some elements may be underestimated. Now, there is a pressing need for extraction of species from deposited particles using suitable solvent.

Other type of chemical element of concern is polychlorinated biphenyls (PCBs), which is used by several industries. PCBs coexist in the atmosphere in both the gas and particle phases. PCBs do not readily break down and therefore may remain in the atmosphere for a long period of time. Once released to the atmosphere, PCBs may repeatedly cycle between atmosphere, land and water bodies. This cycle can extend over long time periods, resulting in the transport of the compounds to long distances. A high volume sampler equipped with glass fiber filter can be used for the collection of particulates and polyurethane foam (PUF) adsorbent for sampling PCBs in the vapor phase. As PCB partitioning between the gas phase and the particulate phase, the total atmospheric concentration of PCB in the gas phase and the particulate phase (sum of the filter retained and adsorbent retained compounds) should be reported. Due to low concentration of PCBs in ambient air, constraint associated with PCB measurement is that it requires very large volume of air (1000–2000 m³) and a minimum sampling time of 24 h is required to get a rough estimate of PCB. Knife-edged surrogate surface can be used to collect particle-phase PCB. After extraction procedure, PCB analysis is performed by means of gas chromatography. Field blanks and quality control samples should also be used. Sampling of PCB (both particulate phase and vapor phase) to measure its flux is not yet standardized. Once when knife-edged surrogate surface was used, short-term PCB fluxes were higher than long-term fluxes. This could be due to evaporation of PCB from deposited particles onto the greased surfaces during long-term sampling. To a certain extent, water surface sampler can be used to collect particulate phase of PCB. But this sampler cannot be used to measure its vapor phase effectively since solubility of PCB in water is low. Now, the need of the hour is to enumerate a consolidated method to collect both phases of PCB.

Deposition of particles

The mechanism of deposition of particles depends on the particle size. Large particles with diameter greater than 10 µm fall slowly by gravitational settlement. Larger the particle, more rapid is their fall.

Particles larger than 150 µm diameter, having settling velocity approximately 1 m/s, remain airborne for a very short time. Particles less than 5 µm have sedimentation velocities, which are so slow that their movement is determined by the natural turbulence of air, just as for gases.

Intermediate particles, between 1 and 10 µm diameter, can be removed by impaction onto leaves and other obstacles. Particles in the range of 0.1–1 µm, which

include most of nitrates and sulfates, are only removed very slowly by dry deposition. The most likely route for their removal is rainout followed by water vapor condensation and droplet growth in clouds. Washout is not very efficient for these fine particles although it becomes more significant for larger particles such as coarse dust (Harrison et al. 2006).

Meteorological factor

If particulate matter has to be settled, atmospheric turbulence is going to play a major role over it. Two meteorological parameters that influence atmospheric turbulence are friction velocity (U^*) and surface roughness (Z_0) (Noll and Fang 1989). The relationship between these parameters for near-neutral atmospheric stability is:

$$U = U^*/k \ln(Z - d/Z_0) \quad (2)$$

where U is the average wind speed, Z is the measured height above ground (usually 10 m) and k is the Von Karman's constant. Von Karman's constant is a dimensionless constant describing logarithmic velocity profile of turbulent fluid flow, typically with a value 0.4. Z_0 is the surface roughness coefficient; d is the datum displacement. A graphical procedure is used to determine U^* and Z_0 . If the logarithm of wind speed for near-neutral atmosphere stability is plotted against function of height, a constant Z_0 is adjusted until a straight line is obtained on semilogarithmic paper. If numerical data are substituted, it could be inferred that the friction velocity might be a few percent of average wind speed (Sehmel 1980). In addition to wind speed, temperature and relative humidity influence dry deposition. Dry deposition velocity strongly depends on wind speed. Higher the wind speed, higher is the friction velocity which accelerates transport of particulate matter. This fact could be found in several works, indicating that a strong positive correlation exists between dry deposition velocity and wind speed. In most of the studies, dry deposition flux was well correlated with wind speed. But in some studies, these parameters had been poorly correlated. This could be due to the fact that the concerned sampling could have been conducted after a heavy downpour which scavenges particles down to ground.

Another meteorological factor, namely relative humidity, also influences dry deposition velocity. Increase in relative humidity would lead to increase in particle size (hygroscopic growth). This growth can significantly increase the particle deposition rate. However, if the growth is not significant (dry season), relative humidity effect is considered to be minor.

There have been several contradictory reports about the relationship between temperature and dry deposition velocity. In general, higher the temperature, stronger the

atmospheric mixing, that decreases the stability of the atmosphere. The decrease in the stability of atmosphere would result in turbulence effect of air. This turbulence would cause dispersion of particles, when particle concentration is high. Thus, dry deposition velocity is reduced. This would rise to negative correlation between temperature and dry deposition velocity. Furthermore, if temperature increases, momentum of particle increases paving way for increase in deposition velocity, if particles fall in coarse particle range. In this case, positive correlation would occur. For fine particles, this momentum effect is considered to be minor. With temperature, when particles show any or a combination of the aforesaid behaviors, it can be determined where there exists a positive or negative correlation between temperature and dry deposition velocity.

Influence of terrain sources

To determine the contribution of terrain sources to the measured concentration and dry deposition fluxes, soil samples are collected around the sampling point to find out the enrichment factor. Enrichment factor is calculated by using following Eq. (3) keeping Al as reference element.

$$\text{Enrichment factor (EF)}_{\text{crust}} = (\text{Tr}/\text{Al})_{\text{air}}/(\text{Tr}/\text{Al})_{\text{crust}} \quad (3)$$

where $(\text{Tr}/\text{Al})_{\text{air}}$ is the concentration ratio of the trace element (Tr) to Al in the air-suspended particles; $(\text{Tr}/\text{Al})_{\text{crust}}$ is the average ratio in local soil. By convention, an arbitrary average $(\text{EF})_{\text{crust}}$ value of <10 is taken as indication that a trace metal in an aerosol has a significant crustal source.

Relationship between dry deposition flux and concentration

From the literature review (Lestari et al. 2003), it is well known that dry deposition flux is directly proportional to particle concentration as per Eq. (4).

$$f = CV_d \quad (4)$$

where f = dry deposition flux ($\mu\text{g}/\text{m}^2/\text{h}$), C = ambient particulate concentration ($\mu\text{g}/\text{m}^3$), V_d = dry deposition velocity (m/h).

The dry deposition fluxes of a pollutant depend on its ambient concentrations. Thus, theoretically, measured fluxes and concentrations should have a strong correlation (Yi et al. 2006). In theory, particles with small variations in their dry deposition velocity should have better correlation between their flux and their concentration since the change in flux is primarily due to the change in concentration. However, two factors might decrease the correlation. The first factor is related to the measurement errors caused by

the uncertainties of the instruments that are collecting atmospheric materials and the subsequent analytical artifacts. The second factor is the validity of the assumption that a surrogate surface represents the natural surface in the collection of pollutants. If the instrument-related errors are assumed to be relatively small, the second factor could be the major cause of any poor correlation between the measured concentrations and fluxes. Such an analysis could provide an assessment of the suitability of using surrogate surfaces for dry deposition measurements. In a generally accepted sense, strong correlations should exist between flux and concentration. But in some circumstances, the correlations can be weak. For example, if every low concentration corresponds to a large dry deposition velocity, the flux would be close to a constant. Furthermore, if the concentration (or dry deposition velocity) stayed constant and all the variations in the fluxes are explained by variations in the dry deposition velocity (or the concentrations), the flux and the concentration would have no correlation. These extreme conditions are unlikely in the real world (Zhang et al. 2012). In addition to the above explanation, dry deposition samples should be carefully transported to laboratory for analysis, failing which causes to cause poor correlation between flux and concentration. Another situation in which moderate correlation can be expected is inclement weather especially at night, scavenging particle down to earth, leaving some fraction of particles to contribute to flux and concentration.

If the measured flux and concentration data fitted into Eq. (4), sometimes vertical intercepts (positive or negative) can be obtained. The negative intercept indicates the contribution of upward flux. Particle deposition mechanisms such as impaction, interception and Brownian diffusion have been conventional mechanisms to collect particles whose usual movement is supposed to be a combination of horizontal and downward movements. Resultant of these would be the cause for deposition. But the particles, whose upward inertial motions are great enough to overcome sedimentation, could be the cause for negative flux. The positive intercept might be the cause of possible error in measurements.

Discussion on various dry deposition velocity models

It is convenient to consider dry deposition of particles as occurring in three steps. In the first step, particles are transported from free atmosphere down to viscous sub-layer that envelops all surfaces. Second, the particles are transported across viscous sub-layers by Brownian diffusion, phoretic effects, interception, inertial forces such as impaction and sedimentation. Finally, the particles interact

with the surface: They may adhere or bounce off. These processes are incorporated into model formulations (Ruijgrok et al. 1995). The dry deposition velocity is often used to quantify the deposition process. The dry deposition velocity V_d is defined as the flux divided by the airborne concentration at a certain reference height. The deposition velocity is highly dependent on particle size with different removal processes in different size regions. Several models are available describing the dry deposition velocity of particles as a function of particle size, based on mathematical relations describing each removal process.

A variety of models have been developed to predict deposition velocities. For example, Slinn and Slinn (1980, 1981) developed a model for particles deposited on a water surface that describes delivery from free atmosphere by eddy diffusion and sedimentation, followed by transport across the viscous layer by Brownian diffusion, inertial impaction and sedimentation. Williams (1982) developed a similar model that includes separate expressions for smooth and rough areas of water surface. Both of these models assumed the water as a perfect sink. Williams' model separates the atmosphere below reference height into two layers. Particulate transfer through the upper layer is governed by turbulent transfer and gravitational settling. In the deposition layer, transfer can follow two parallel paths in addition to gravitational settling. One path is controlled by transfer resistance from air to smooth water surface. The other path is the transfer to the fraction of the water surface that is broken due to formation of spray and bubbles. Horizontal transfer between the smooth and broken areas represents an interaction effect. In addition, gravitational settling in lower layer is adjusted for particle growth due to high relative humidity. The intent of Williams' model is to examine the importance of wind speed, air/water temperature difference, relative humidity, broken surface transfer and dry particle size on deposition velocity (Qi et al. 2005).

Williams' model included the growth effects of particles under high humidity. Hence, if atmosphere relative humidity is significant, the humidity effect must be included. The difficulty associated with Williams' model was inclusion of a lot of coefficients (lateral transfer coefficient, turbulent transfer coefficient, broken surface transfer coefficient, smooth surface transfer coefficient, turbulent transfer resistance, broken surface transfer resistance, smooth surface transfer resistance and lateral transfer resistance) to evaluate dry deposition velocity. Measurement/calculation of every coefficient may lead to error. Hence, calculated dry deposition velocity would reflect cumulative error of all coefficients. Subsequent researchers added the effects of a non-perfect sink surface by including a surface resistance term. Williams' model under-predicted for particles greater than $4 \mu\text{m}$ and over-predicted for

particles between 0.5 and 4 μm . Then, Qi et al. (2005) modified Williams' model to predict humidity effect on dry deposition velocity. Measured dry deposition flux and particle diameter data from Zufall et al. (1998) and Caffery et al. (1998) were used to evaluate Williams' and modified Williams' model. By comparison, results of the modified Williams' model agreed well with that of measurement.

Since these types of models are complex and require information that is often difficult to obtain, dry deposition is often estimated using total or partially size-segregated particle concentrations and average or overall deposition velocities. These deposition velocities are difficult to predict because they vary with atmospheric conditions, location and size distribution of the depositing species. It is common to have one order of magnitude variations in calculated overall deposition velocities due to differences in methods. All these methods have employed particle size distribution to calculate dry deposition velocity (Van Aalst 1988). The number of steps used to discretize the particle's size range has a large influence on the computed dry deposition velocity (Dullac et al. 1989) due to the nonlinear dependence of the calculated deposition velocity on particle diameter and shape of the size distribution curve. For these reasons, the use of an overall deposition velocity, in combination with measured ambient concentrations, to estimate dry deposition, often greatly underestimates the contribution of coarse particles, particularly those $>10 \mu\text{m}$, to dry deposition (Holsen et al. 1991; Holsen and Noll 1992).

The inferential method involves indirect estimation of dry deposition rates on the basis of routinely measured air concentrations and meteorological parameters. V_d is estimated on the basis of resistance models and can be defined as the inverse of the sum of multiple resistance factors [aerodynamic resistance (R_a), boundary layer resistance (R_b) and surface resistance (R_c)] (Wesley and Hicks 2000): Dry deposition velocity in previously used dry deposition models is computed from a formula analogous to Ohm's law in electrical circuits, as follows (5).

$$V_d = (R_a + R_b + R_c)^{-1} \quad (5)$$

Aerodynamic resistance is inversely proportional to wind speed. In other words, as wind speed approaches zero, aerodynamic resistance approaches infinity. This could reduce dry deposition velocity to zero. Particulate matter is first transported through bulk atmosphere. Aerodynamic resistance would govern the transport of particles from the atmosphere to surrogate surface. R_a includes stability correction term to take into account the effect of buoyancy-induced changes in flux–gradient relationships. It is generally assumed that the pollutant transfer is similar to that for heat. However, the surrogate surface is the thin skin of unperturbed air that is called the boundary layer.

Transport of particles through this boundary layer is by molecular diffusion. Resistance induced by this layer is called boundary layer resistance. The magnitude of this resistance depends mainly on the depth of the boundary layer. Boundary layer resistance can be parameterized as a function of a Schmidt number (S_c), which is nothing but the ratio of kinematic viscosity of air to molecular diffusivity. In this layer, it is assumed that particles are affected by Brownian diffusion and inertial impaction. In a generally accepted sense, turbulence of atmosphere would reduce boundary layer resistance. Surface resistance is determined by affinity of surface for the given particles. If the surface is perfect sink, surface resistance would be zero. Water surface is usually assumed a perfect sink for pollutant. Hence, if water surface sampler is used to obtain dry deposition sample, surface resistance would be taken as zero. Hence, this term would not contribute to dry deposition velocity. For this condition, R_c is assumed to be zero. This assumption came from the fact that particles can penetrate the deposition layer and stick to the surface.

In the dry deposition velocity model (Eq. 5), in addition to resistance, if a term gravitational settling velocity is also included, that model can be applied to both bulk and size-segregated dry deposition velocity.

For these kinds of models with inadequate dry deposition formulations, adding or improving a resistance approach would have been desirable. Resistance models, however, are inapplicable to aerodynamically very rough surfaces such as urban areas. However, it is also derived that in the longer term an improved parameterization of dry deposition needs to be developed that will be applicable to all surfaces and in particular urban surfaces.

The limitations of the model (Eq. 5) lie in the uncertainty and variability of the model input data such as time- and species-dependant parameters. Therefore, these parameters may give rise to significant uncertainties in the simulation results, and it is very important to know the effect of the individual input parameters on model output. Nonlinear models, such as most of the deposition models, can magnify the uncertainties of some parameters and damp others. Hence, in many cases, these models may overestimate or underestimate dry deposition fluxes through the calculation of dry deposition velocity.

To predict particulate dry deposition velocity, Sehmel and Hodgson model was also emerged. The Sehmel and Hodgson particle dry deposition velocity is a three-box mass transfer model that uses mass transfer resistance to describe the deposition velocity from a reference concentration height to the deposition surface (Lin et al. 1993). Sehmel and Hodgson proposed an empirical model based on curves fit to wind tunnel deposition results for a range of soil surface covers. Sehmel and Hodgson model is given in Eq. (6).

$$V_d = V_t / 1 - \exp\{V_t / U^* \text{Int}\} \quad (6)$$

where V_d is the particle dry deposition velocity, V_t is the particle terminal settling velocity, U^* is the friction velocity and Int is the resistance integral involving dimensionless eddy and Brownian diffusivity between the concentration reference height and the deposition surface. Information about the integral term is available elsewhere (Lin et al. 1993). This model generally under-predicted dry deposition velocity for particles in the 5–80 μm size range (Lin et al. 1994; Sofuoglu et al. 1998). The large particle diameter used by Sehmel and Hodgson in their wind tunnel experiments was 29 μm . Their curves beyond this value are extrapolations. This model takes into account supermicron particles eddy diffusivity, gravitational settling and particle inertia as the prime mechanism influencing the deposition to a terrestrial receptor. Finally, the model combines this term with terminal settling velocity and Brownian diffusion to predict dry deposition velocity. For more turbulent atmospheric conditions (unstable condition), the rate of dry deposition will tend to increase, bounded by the extent of eddy diffusion rather than surface processes.

Fang et al. (1999) apply a “Noll and Fang” dry deposition model based on measurements of the deposition of atmospheric particles to surrogate surfaces. Fang et al. (1999) developed an empirical model relating particle settling velocity, friction velocity and particle diameter as shown in the following Eq. (7).

$$V_d = V_s + 1.12 U^* \exp(-30.36/D_p) \quad (7)$$

where V_d = dry deposition velocity (cm/s), V_s = particle settling velocity (cm/s), D_p = particle diameter (μm), U^* = friction velocity (m/s).

Friction velocity is a measure of surface stress reflecting the effects of surface roughness and wind speed.

Noll and Fang model generally fits better for estimating dry deposition flux of coarse particle. It is substantiated as this model fits daytime dry deposition flux better than nighttime, since dry deposition flux is dominated by coarse particles in daytime. Comparison of the Noll and Fang model and the Sehmel and Hodgson model indicated that the Noll and Fang model predicted more accurately than Sehmel and Hodgson model (Fang et al. 1999).

Mariraj Mohan and Rajagoal (2012) developed particle dry deposition velocity model for a city with an ensemble of population, traffic, research centers and highways (semi-urban area). The dry deposition velocity model is presented in Eq. (8).

$$\log V_d = 7.240 \times V_s^{0.019} \times U^{-0.026} \times h^{0.004} / v^{-0.778} \quad (8)$$

where V_d is the dry deposition velocity, V_s particle terminal settling velocity, U is the average wind speed, h is the

height at which sampling is done, v is the kinematic viscosity of air which is strongly depending on temperature.

Data were obtained in the model (Eq. 8) for wind speed ranging from 2.9 to 7.1 km/h, temperature 28–35 °C, particle size 10 to 174 μm and height of sampling between 4.7 and 8.1 m. For these specified ranges, when the empirical model was developed, the exponential coefficients were determined as 0.019, 0.026, 0.004 and 0.778 for wind speed, particle settling velocity, height at which sampling was performed and kinematic viscosity, respectively. Since the coefficient of kinematic viscosity of air assumes a value of 0.778 compared to other values ranging from 0.004 to 0.026, it can be concluded that kinematic viscosity is sensitive than other parameters. By observing the coefficients in Eq. (8), it can be said that height has not played significant role in dry deposition velocity model since it assumes a low value of 0.004.

Furthermore, topography of a rough surface distorts the air flow characteristics and the boundary layer itself, resulting in a shorter stopping distance for the deposited particle. (Stopping distance indicates the ability of a particle to respond to a new condition). As a result, dry deposition velocity is increased over a rough surface. Hence, it can be inferred that if dry deposition velocity model is developed with some rough surface it would yield higher dry deposition velocity than a model developed with smooth surface.

Influence of particle size on dry deposition velocity

In order to evaluate the influence of particle size on dry deposition velocity, 50 numbers of particle size data were used in this study. Particle size data were collected in a semi-urban area. Particle size ranges were classified as 10–29, 32–40, 40–64, 67–91 and 92–174 μm . Keeping other parameters as constant, particle size data were fitted into model Eqs. (7) and (8). In Noll–Fang model, particle size did not correlate well in the particle size range 32–40 μm ; poor correlation was obtained (0.54) in that range: Better correlation was obtained in other particle size ranges. For all particle size ranges, model Eq. (8) fitted well, indicating that the model has better regional suitability (semi-urban area) over Noll–Fang model.

As far as Yun et al. (2002) is concerned, in Sehmel–Hodgson model, as the particle size increases by a factor of 10, the dry deposition velocity increases by a factor of 1000, indicating that the dry deposition velocity depends strongly on particle size. In Noll–Fang model, based on the observed particle size values in a semi-urban area, with the increase in particle size by a factor of 10, the dry deposition velocity increases by a factor of 97 approximately. In Mariraj Mohan and Rajagoal model, with the increase in



particle size by a factor of 10, the dry deposition velocity increases by a factor of 6. This clearly indicated that particle size is the most sensitive parameter in Sehmel–Hodgson model, moderately sensitive in Noll–Fang model, whereas less sensitive in the model represented by Eq. (8). In other words, in Sehmel–Hodgson model, physical nature of a particle occupies a commanding position than the environmental conditions (wind speed, temperature, etc.). But in the model Eq. (8), rather than the particle size, environmental conditions (wind speed, temperature, etc.) govern dry deposition. Equation (8) was developed with temperature ranges between 28 and 35 °C. Hence, it can be inferred that in tropical countries temperature plays a major role in dry deposition. This fact was further verified when a higher coefficient (0.778) was obtained for kinematic viscosity of air in Eq. (8), since kinematic viscosity of air is a strong function of temperature. Influence of particle size on dry deposition velocity was also discussed in “[Deposition of particles](#)” section.

Suitability of model

Noll–Fang dry deposition model was applied in various areas such as institutional, commercial, residential, area surrounded by trees, inside university campus—Chicago (comprising of low-rise building, landscape area, asphalt parking lot), trafficked area, rural area, etc. Among aforesaid areas, it predicted dry deposition velocity well in trafficked area. It under-predicted the same in rural area. It overpredicted when applied inside university campus. Noll–Fang developed the model by quantifying inertial deposition of coarse particles to a smooth surface under atmospheric conditions by simultaneous collection of atmospheric particles with NRI and dry deposition flux with a surrogate surface. Since trafficked area consists of appreciable fraction of coarse particles; dry deposition velocity was well predicted in trafficked area by Noll–Fang model.

In most of the previous studies, Sehmel–Hodgson model was used in a mixed area consisting of mixed of institutional, commercial and residential sites. It could be observed that Sehmel–Hodgson model began to under-predict dry deposition velocity as particle size increases to approximately 80 μm . For particles in the range of 0.18–6 μm , this model overpredicted dry deposition velocity. Hence, it can be inferred that, irrespective of difference types of areas, this model predicted dry deposition velocity better based on particle size.

Mariraj Mohan and Rajagopal model is suited well for a semi-urban area consisting of residential, institutional and trafficked sites. For all dry deposition models including the

model by Eq. (8), the usual assumption is that particles are spherical. Another important assumption of this model (Eq. 8) is that particle density was assumed to be 1 g/cc. However, particles released from various sources may not be having a density of 1 g/cc. If particle density dominates dry deposition velocity, the model by Eq. (8) tends to under-predict that scenario.

Dry deposition velocity

Dry deposition is characterized by dry deposition velocity, which is the relation between dry deposition flux and contaminant particle-phase concentration (Tasdemir et al. 2004).

Strictly speaking, dry deposition velocity is not a real velocity; however, it is referred to as velocity because of its units (Zannetti 1990). One situation where dry deposition velocity may be considered a real velocity is when gravitational settling controls deposition as in the case for large particles. Impaction and interception were also important for larger size particles ($D_p = 5 \mu\text{m}$) (Zhang et al. 2001). For very small particle ($D_p < 0.1 \mu\text{m}$), Brownian movement dominates the deposition velocity (Holsen et al. 1991; Zannetti 1990). Particles in intermediate size range have the lowest predicted deposition velocities because of the relative weakness of their Brownian motion and gravitational settling effects.

In the literature, reported deposition velocities vary a lot possibly due to the spatial fluctuations (urban and non-urban areas), temporal changes (winter and summer months), diurnal variations, surface-type differences and micrometeorological conditions (such as wind velocity and direction, atmospheric stability) as well as experimental uncertainties (Finlayson-Pitts and Pitts 1986).

Previous study (Davidson et al. 1985) suggested that dry deposition velocity of particulate-phase pollutant is decreased by use of rain shield in collecting dry deposition samples. Manual operation of dry deposition collectors came about from this point.

Particle deposition data such as particle size, wind speed, deposition surface and dry deposition velocity from various literatures have been presented in Table 1. From Table 1, it is observed that increase in particle size leads to increase in dry deposition velocity. In addition to particle size, wind speed is understood to have a great influence on dry deposition velocity. Previous works suggested that, for particles $<0.1 \mu\text{m}$ diameter, dry deposition velocity decreased with increase in particle diameter. For particle diameter, $>0.1 \mu\text{m}$ dry deposition velocity increases with particle diameter; for coarse particles, this may be due to

Table 1 Dry deposition velocities for particles

S. no.	Depositing material	Particle size (μm)	Wind speed (m/s)	Depositing surface	Dry deposition velocity (cm/s)	References
1.	Particles	0.03–30	–	Microscopic slides	10^{-3} –40	Sehmel and Holsen (1978)
2.	Particles	160.7 ± 151.3	0.9–4.4	Greased Mylar strip	5.7–23.1	Noll et al. (1988)
3.	Coarse particles	5–100	–	Greased Mylar strip	0.055–10	Noll and Fang (1989)
4.	Particulate matter, Pb, Ca	0.2–100	3.2–6.2	Greased Mylar strip	0.01–100	Lin et al. (1993)
5.	PAH	–	0.53–3.03	Greased Mylar strip	0.15–2.8	Sheu et al. (1996)
6.	Particulate sulfate	–	1.74–5.05	Water surface sampler	0.66–0.93	Yi et al. (1997)
7.	Particulate species	0.25–100	3.3–6.3	Teflon filters	0.05–10	Zufall et al. (1998)
8.	PM, Ca^{2+} , Mg^{2+} , NH_4^+ , SO_4^{2-}	0.05–100	1.0–2.6	Greased Mylar strip	0.11–3.93	Fang et al. (1997)
9.	PM ₁₀ , Al, Mg	0.2–60	–	Greased Mylar strip	0.02–3.2	Sofuoglu et al. (1998)
10.	Particles	0.1–100	3.02–5.89	Greased Mylar strip	0.1–100	Noll et al. (2001)
11.	Anthropogenic elements (V, Cr, Cu, Zn, Mo, Ba, Pb)	–	–	Greased Mylar strip	0.3–23.1	Yi et al. (2001a, b)
12.	Trace metals	0.1–35	4.2–6.2	Impaction plate	0.1–13.8	Brewer and Belzer (2001)
13.	PM, Ca, Al	0.2–8.0	–	Greased Mylar strip	23.1–35.5	Yi et al. (2001a, b)
14.	PAH	–	2.6–3.9	Greased Mylar strip	2.0–8.0	Vardar et al. (2002)
15.	Metals	0.5–60	–	Greased Mylar strip	0.11–0.4	Yun et al. (2002)
16.	PM, SO_4 , NO_3	0.09–33.06	2.18–5.89	Greased Mylar strip	0.21–89.3	Lestari et al. (2003)
17.	PAH	–	–	Teflon-coated surface	0.07–0.63	Poor et al. (2004)
18.	Particles	–	2–20	Teflon-coated surface	0.8–100	Qi et al. (2005)
19.	Trace metal (As, Mn, Fe, Zn, Cr, Cu, pb)	Max size 100	3.0–7.0	PS I instruments	0.15–3.31	Zhang et al. (2012)
20.	PAH	–	–	Stainless steel funnel	0.21 ± 0.08	Liu et al. (2013)
21.	PM ₁₀	–	5–23	–	0.19–8.17	Yan et al. (2014)

gravitational settling. Actually, dry deposition velocity is a combination of horizontal velocity (wind speed) and terminal settling velocity (V_s). Resultant velocity of wind speed and V_s quantifies dry deposition velocity. For particles, $<0.1 \mu\text{m}$, the scenario would be different. Brownian diffusion comes into picture for fine particles. Fine particle can be easily carried away with wind speed. Period of suspension in ambient air will be more. For very fine particles ($<0.1 \mu\text{m}$), particle agglomeration might also occur. This agglomeration would be responsible for dry deposition velocity for these diameter ranges.

There has been a lot of study about particle dry deposition on terrains. But a few studies were available to evaluate the impact of particle dry deposition over sea. In this context, the Shi et al. (2013) study is notable. Shi et al. (2013) conducted a study on concentration, solubility and deposition flux of atmospheric particulate nutrients over the Yellow Sea. Dry deposition velocity of their study was 0.68 cm/s during storm period and 0.22 cm/s during normal days. Comparing particle dry deposition velocity of the terrain, these values are very low. Lower dry deposition velocity indicates lower dry deposition flux. Over sea, there

are a few emission sources comparing to terrestrial terrain. Major emission source over sea could be storm period, ship exhaust.

In a generally accepted sense, coarse particles have higher dry deposition velocity than fine particles. The type of sampling site environment is another factor to influence dry deposition velocity. For example, if a site is surrounded by trees, leaves of the trees can help capture suspended particles and reduce the pollutant in air. This could be another reason for obtaining lower dry deposition velocity.

Summary and conclusion

The significance of dry deposition is given in various literatures. Various particulate dry deposition methods are natural surfaces, surrogate surfaces and water surfaces. Every method has its own limitations. Efficiency of a method is usually judged by its removal efficiency. To ascertain this, known quantity of material is spiked onto dry deposition plate and extraction procedure is performed. This kind of experiment may produce good result on

overall particulate dry deposition, which is a direct function of mass of particle deposited. But extraction of certain species has not been 100 %. One kind of surrogate surface may be good enough for particular species, whereas the same surface may fail for some other species. Now, the need of the hour is to develop a surrogate surface for dry deposition which produces very good result for all the species.

Various mathematical models to predict dry deposition velocity are almost regionally fit. Applicability of particular model to some other region may fail as per available literature. In this context, we need to have a next-generation model, which has wider spatial and temporal suitability. Many dry deposition results are needed to gain an in-depth knowledge on transport and subsequent mass transfer (advection and diffusion are major phenomena for particle to transport, and gravitational settling is the prime factor for coarse particle to deposit).

Reader is suggested to go through the past publications mentioned in the reference section and other similar works.

Acknowledgments The author would like to thank reviewers who offered valuable suggestions to improve the manuscript. The author also extends his thanks to Dr. S. Madhu, for his advice and sharing his experience.

References

- Brewer R, Belzer W (2001) Assessment of metal concentrations in atmospheric particles from Burnaby Lake, British Columbia, Canada. *Atmos Environ* 35:5223–5233
- Caffery PF, Ondov JM, Zufall MJ (1998) Determination of size-dependant dry particle deposition velocities with multiple intrinsic tracers. *Environ Sci Technol* 32(11):1615–1622
- Chang CN, Fang G-C, Chang S-Y (1994) Comparison of dry deposition fluxes among three different places near Taichung city. *Tunghai J* 35:107–123
- Davidson CI, Lindberg SE, Schmidt JA, Cartwright LG, Landis LR (1985) Dry deposition of sulphate onto surrogate surfaces. *J Geophys Res* 90(D1):2123–2130
- Dloske DA (1995) Deposition of atmospheric pollutants to monuments, statues and buildings. *Sci Total Environ* 167:15–31
- Dolske DA, Gatz DF (1985) A field comparison of methods for the measurement of particle and gas deposition. *J Geophys Res* 90:2076–2084
- Dullac F, Buat-Menard P, Ezat U, Melki S, Bergametti G (1989) Atmospheric input of trace metals to the Western Mediterranean: uncertainties in modeling dry deposition from cascade impactor data. *Tellus* 41B:362–378
- Fairall CW, Larsen SE (1984) Dry deposition surface production and dynamics of aerosols in the marine boundary layer. *Atmos Environ* 18:69–77
- Fang GC, Cheng M-T, Chang C-N (1997) Monitoring and modeling the mass, heavy metals and ion species dry deposition in Central Taiwan. *J Environ Sci Health A* 32(8):2183–2199
- Fang GC, Wu YS, Chang CN, Chang KF, Yang DG (1999) Modeling dry deposition of total particle mass in trafficked and rural sites of Central Taiwan. *Environ Int* 25(5–25):625–633. doi:10.1016/S0160-4120(99)00021-5
- Fang F, Wang Q, Li J (2001) Atmospheric particulate mercury concentration and its dry deposition flux in Chanchun city, China. *Sci Total Environ* 281:229–236
- Fang GC, Chang S-C, Chen Y-C, Zhuang Y-J (2014) Measuring metallic elements of total suspended particulates (TSPs), dry deposition flux and dry deposition velocity for seasonal variation in central Taiwan. *Atmos Res* 143:107–117
- Finlayson-Pitts BJ, Pitts JN (1986) *Atmospheric chemistry: fundamental and experimental techniques*. Wiley, New York
- Flechard CR, Nemitz E, Smith RI, Fowler D, Vermeulen AT, Bleeker A, Erismann JW, Simpson D, Zhang L, Tang YS, Sutton MA (2011) Dry deposition of reactive nitrogen to European ecosystems: a comparison of inferential models across the NitroEurope network. *Atmos Chem Phys* 11:2703–2728. doi:10.5194/acp-11-2703-2011
- Goss NR, Mladenov N, Seibold CM, Chowanski K, Seitz L, Wellemeyer TB, Williams MW (2013) Quantifying particulate matter deposition in Niwot Ridge, Colorado: collection of dry deposition using marble inserts and particle imaging using the FlowCAM. *Atmos Environ* 80:549–598
- Harrison RM, Abdalmogith SS, Derwent RG (2006) Particulate sulphate and nitrate in Southern England and Northern Ireland during 2002/3 and its formation in a photochemical trajectory model. *Sci Total Environ* 368:769–780
- Holsen TM, Noll KE (1992) Dry deposition of atmospheric particles: application of current models to ambient data. *Environ Sci Technol* 26(9):1807–1814
- Holsen TM, Noll KE, Liu SP, Lee WJ (1991) Dry deposition of polychlorinated biphenyls in urban areas. *Environ Sci Technol* 25:1075–1081
- Kaufman YJ, Tanre D, Boucher O (2002) A satellite view of aerosols in the climate system. *Nature* 419(6903):215–223
- Kellogg RB (1992) Standard operating procedure for the source apportionment research branch LBL energy dispersive X-ray fluorescence spectrometer. Contract report 68-DO-0106, Atmospheric research and assessment laboratory, US Environmental Protection Agency, Research Triangle Park, NC
- Lee WJ, Chun-Ching S, Sheu H-L, Fan Y-C, Chao H-R, Fang G-C (1996) Monitoring and modeling of PCB dry deposition in urban area. *J Hazard Mater* 49:57–88
- Lestari P, Oskouie AK, Noll KE (2003) Size distribution and dry deposition of particulate mass, sulphate and nitrate in an urban area. *Atmos Environ* 37:2507–2516
- Lin JM, Fang G-C, Holsen TM, Noll KE (1993) A comparison of dry deposition modeled from size distribution data and measured with a smooth surface for total particle mass, lead and calcium in Chicago. *Atmos Environ* 27A(7):1131–1138
- Lin JJ, Noll KE, Holsen TM (1994) Dry deposition velocities as a function of particle size in the ambient atmosphere. *Aerosol Sci Technol* 20:239–252
- Liu F, Xu Y, Liu J, Liu D, Li J, Zhang G, Li X, Zou S, Lai S (2013) Atmospheric deposition of polycyclic aromatic hydrocarbon (PAHs) to a coastal site of Hong Kong, South China. *Atmos Environ* 69:265–272
- Mariraj Mohan S, Rajagoal K (2012) Development of dry deposition velocity model for a typical medium level Indian city Karaikudi. *Int J Environ Eng* 4(1/2):145–168
- Maro D, Boulard D, Copalie A, Germain P, Hebert D, Tenailleau L (2004) Validation of dry deposition models for submicronic and



- micronic aerosols. In: Proceeding of the 9th international conference on harmonization within atmospheric dispersion modeling for regulatory purposes, Garmisch-Partenkirchen, 1–4 June 2004, pp 89–94
- Maro D, Connan O, Flori JP, Hebert D, Mestayer P, Olive F, Rosant JM, Rozet M, Sini JF, Solier L (2014) Aerosol dry deposition in urban environment: assessment of deposition velocity on building facades. *J Aerosol Sci* 69:113–131
- Noll KE, Fang KYP (1989) Development of a dry deposition model for atmospheric coarse particles. *Atmos Environ* 23(3):585–594
- Noll KE, Fang KYP, Watkins LA (1988) Characterization of the deposition of particles from the atmosphere to a flat plate. *Atmos Environ* 22(7):1461–1468
- Noll KE, Jackson MM, Oskouie AK (2001) Development of an atmospheric particles dry deposition model. *Aerosol Sci Technol* 35:627–636
- Odabasi M, Muezzinuglu A, Bozlaker A (2002) Ambient concentration and dry deposition fluxes of trace elements in Izmir, Turkey. *Atmos Environ* 36(38):5841–5851
- Ould-Dada Z, Copplestone D, Joal M, Shaw G (2002) Effect of forest edges on dry deposition of radioactive aerosols. *Atmos Environ* 36:5595–5601
- Paode RD, Holsen TM (1996) Standard operating procedure for preparation, handling and extraction of dry deposition plates: dry deposition of atmospheric particles. Revision 2
- Petroff A, Zhang L (2010) Development and validation of a size-resolved particle dry deposition scheme for application in aerosol transport models. *Geosci Model Dev* 3:753–769. doi:10.5194/gmd-3-753-2010
- Poor N, Tremblay R, Kay H, Bhethanabotla V, Swartz E, Luther M, Campbell S (2004) Atmospheric concentrations and dry deposition rates of polycyclic aromatic hydrocarbons(PAHs) for Tampa Bay, Florida, USA. *Atmos Environ* 38:6005–6015
- Qi J, Li P, Li X, Feng L, Zhang M (2005) Estimation of dry deposition fluxes of particulate species to the water surface in the Qingdao area, using a model and surrogate surfaces. *Atmos Environ* 39:2081–2088
- Ruijgrok W, Davidson CI, Nicholson KW (1995) Dry deposition of particles: implications and recommendations for mapping of deposition over Europe. *Tellus* 47B(5):587–601
- Sataka S, Uno I, Takemura T, Carmichael GR, Tang YH, Streets D, Sugimoto N, Shimizu A, Uematsu M, Han JS, Ohta S (2004) Characteristics of Asian aerosol transport simulated with a regional-scale chemical transport model during the ACE-Asia observation. *J Geophys Res.* 109(D19):1–16. doi:10.1029/2003JD003997
- Schwede DB, Zhang L, Vet R, Lear G (2011) An intercomparison of the deposition models used in the CASTNET and CAPMoN networks. *Atmos Environ* 45:1337–1346
- Sehmel GA (1980) Particle and gas dry deposition: a review. *Atmos Environ* 14:983–1011
- Sehmel GA, Hodgson WH (1978) A model for predicting dry deposition of particles and gases to environmental surface. DOE report PNLSA-6721. Pacific Northwest Laboratory, Richland, WA
- Seinfeld J, Pandis SN (1997) Atmospheric chemistry and physics. Wiley-Interscience Publication, New York
- Shahin U, Yi SM, Paode RD, Holsen TM (2000) Long term elemental dry deposition fluxes measured around Lake Michigan with an automated dry deposition sampler. *Environ Sci Technol* 34(10):1887–1892
- Shahin UM, Holsen TM, Odabasi M (2002) Dry deposition measured with a water surface sampler: a comparison to modeled results. *Atmos Environ* 36:3267–3276
- Sheu HL, Lee W-J, Chun-Ching S, Chao H-R, Fan Y-C (1996) Dry deposition of polycyclic aromatic hydrocarbon in ambient air. *J Environ Eng* 122(12):1101–1109
- Shi JH, Zhang J, Gao H-W, Tan S-C, Yao X-H, Ren J-L (2013) Concentration, solubility and deposition flux of atmospheric particulate nutrients over Yellow Sea. *Deep Sea Res II* 97:43–50
- Slinn SA, Slinn WGN (1980) Predictions for particle deposition on natural waters. *Atmos Environ* 14:1013–1016
- Slinn SA, Slinn WGN, Eisenreich SJ (eds) (1981) Modeling of atmospheric particulate deposition to natural waters. Ann Arbor Science Publishers, Ann Arbor, p 23
- Sofuoglu SC, Paode RD, Sivadechathep J, Noll KE, Holsen TM, Keelar GJ (1998) Dry deposition fluxes and atmospheric size distributions of mass, Al, and Mg measured in Southern Lake Michigan during AEOLOS. *Aerosol Sci Technol* 29:281–293
- Tasdemir Y, Odabasi M, Vardar N, Sofuoglu A, Murphy TJ, Holsen TM (2004) Dry deposition fluxes and velocities of polychlorinated biphenyls (PCBs) associated with particles. *Atmos Environ* 38:2447–2456
- USEPA (1996) Compilation of air pollutant emission factors. Volume 1: Stationary point and area sources AP-42, 5th edn
- Van Aalst RM (1988) Input from the atmosphere. In: Salomons W et al (eds) Pollution of the North Sea: an assessment. Springer, Berlin, pp 275–283
- Vardar N, Odabasi M, Holsen TM (2002) Particulate dry deposition and overall deposition velocities of polycyclic aromatic hydrocarbons. *J Environ Eng* 128(3):269–274
- Wesley ML, Hicks BB (2000) A review of the current status of knowledge on dry deposition. *Atmos Environ* 34:2261–2282
- Williams RM (1982) A model for dry deposition of particles to natural water surfaces. *Atmos Environ* 16:1933–1938
- Wu YL, Davidson CI, Dolske DA, Sherwood SI (1992) Dry deposition of atmospheric contaminant: the relative importance of aerodynamic, boundary layer and surface resistance. *Aerosol Sci Technol* 16:65–81
- Yan H, Liu X, Qi J, Gao H (2014) Dry deposition of PM₁₀ over the Yellow Sea during Asian dust events from 2001 to 2007. *J Environ Sci* 26:54–64
- Yang HH, Chiang C-F, Lee W-J, Hwang KP, Wu EMY (1999) Size distribution and dry deposition of road dust PAHs. *Environ Int* 25(5):585–597
- Yi SM, Holsen TM, Noll KE (1997) Comparison of dry deposition predicted from models and measured with a water surface sampler. *Environ Sci Technol* 31(1):272–278
- Yi SM, Shahin U, Sivadechathep J, Sofuoglu SC, Holsen TM (2001a) Overall elemental dry deposition velocities measured around lake Michigan. *Atmos Environ* 35:113–1140
- Yi SM, Lee E-Y, Holsen TM (2001b) Dry deposition fluxes and size distributions of heavy metals in Seoul, Korea during Yellow-sand events. *Aerosol Sci Technol* 35:569–576
- Yi SM, Totten LA, Thota S, Yan S, Offenber JH, Eisenreich SJ, Garney J, Holsen TM (2006) Atmospheric dry deposition of trace elements measured around the urban and industrially impacted NY–NJ harbor. *Atmos Environ* 40:6626–6637
- Yun HJ, Yi S-M, Kim YP (2002) Dry deposition fluxes of ambient particulate heavy metals in a small city, Korea. *Atmos Environ* 36:5449–5458
- Zannetti P (1990) Air pollution modeling, theories, computational methods and available software, computational mechanics. Southampton and Van Nostrand Reinhold, New York
- Zhang L, Vet R (2006) A review of current knowledge concerning size-dependent aerosol removal. *China Particuol* 4(6):272–282



- Zhang L, Gong S, Padro J, Barrie L (2001) A size-segregated particle dry deposition scheme for an atmospheric aerosol module. *Atmos Environ* 35:549–560
- Zhang L, Fang GC, Liu CK, Huang YL, Huang JH, Huang CS (2012) Dry deposition fluxes and deposition velocities of seven trace metal species at five sites in Central Taiwan—a summary of surrogate surface measurements and a comparison with model estimation. *Atmos Chem Phys* 12:3405–3417
- Zheng M, Guo Z, Fang M, Rahn KA, Kester DR (2005) Dry and wet deposition of elements in Hong Kong. *Mar Chem* 97:124–139
- Zufall MJ, Davidson CI, Caffery PF, Ondov JM (1998) Airborne concentrations and dry deposition fluxes of particulate species to surrogate surfaces deployed in Southern Lake Michigan. *Environ Sci Technol* 32:1623–1628

